



Features

- Single axis levelling controller with dual relay output
- Adjustable switching threshold from 0.2 to 4.8°
- 'ZERO' button to set zero after installation
- Small size and low power consumption.
- No moving parts means no servicing and long life
- High precision switching threshold
- Mercury free and RoHS compliant
- Sealed to IP65 and CE certified

Applications

- Man lift platform levelling
- Recreational vehicle auto-levelling
- Roller shutter door controls
- Container levelling
- Can be readily customised to suit most applications



Description

A tilt switch with dual relay outputs designed primarily for levelling systems. The switching threshold is adjusted using the pcb mounted rotary switch. If the tilt exceeds the threshold with clockwise tilt, relay 1 will be switched on, and will switch off when the angle returns to zero (or below). Conversely if the tilt exceeds the threshold with counter clockwise tilt, relay 2 will be switched on, and will switch off when the angle returns to zero (or above). In this configuration the tilt switch can be used

to drive motorised or hydraulic actuators to maintain a system in a level position. To Make installation easy, it can be mounted horizontally or vertically, and there is a switch to set the zero position after installation.

The unit utilises a high precision MEMS sensing element and is available with and without temperature compensation, which improves the accuracy over a wider operating range. These devices are designed, built and tested in our UK factory to guarantee performance to

Specifications

Part Number	ELS-DR-2	ELS-DR-5	Notes
Switching Range	0.2 to 1.7°	1.8-4.8°	Range is adjustable via the 16 position PCB rotary switch
Adjustment Step	0.1°	0.2°	Adjustment resolution of the rotary switch
Switching Accuracy	±0.05°	±0.1°	Switching Accuracy at 20°C
Bandwidth (-3dB)	0.5Hz, 1Hz or 2Hz (See part numbering on page 4)		2nd order Bessel filter on sensor output. Can be factory configured between 0.1 and 16Hz on request
Power Supply	8-35Vdc		Reverse polarity protected internally
Current	10-40mA (with 8V supply)		Increases to 40mA when relay is switched. Current reduces with increasing supply voltage
Relay Switching Capacity	220Vdc, 250Vac 2A 60W		Maximum switching capacity of relays. Relay contact life is shortened depending on switching current. Contact factory for further information
Dimensions	65x60x40mm		PCB only version available on request
Operational Temperature	-40 to 85°C		
Storage Temperature	-40 to 85°C		
Cable Length	2m		
Sealing	IP65		



Housing Drawing

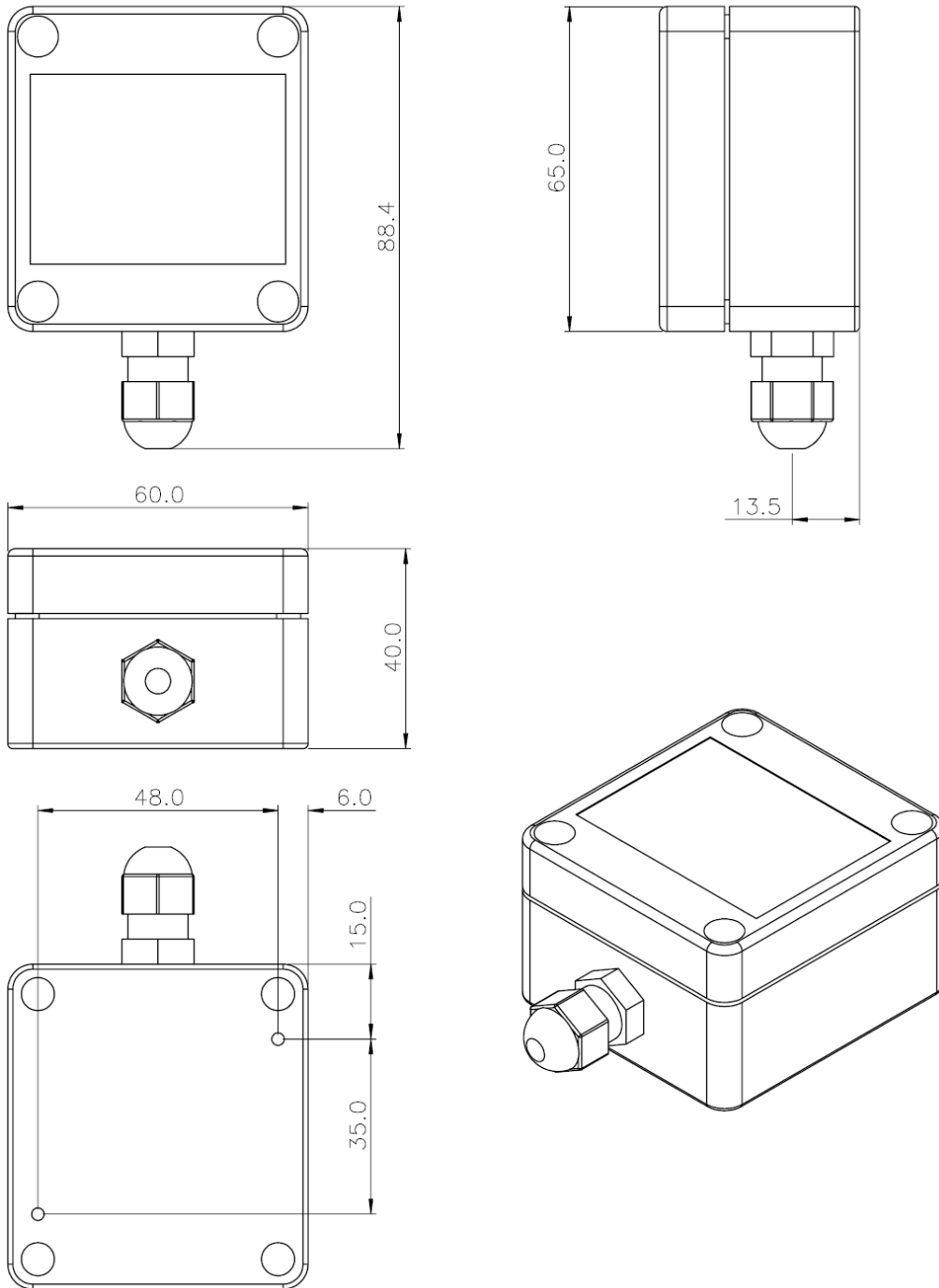

Certification

The products are type approved to in accordance with the following directive(s):

EMC Directive 2004/108/EC

And it has been designed, manufactured and tested to the following specifications:

BS EN61326-1:2006

Electrical equipment for measurement, control and laboratory use – EMC Requirements

BS EN55011:2007, Group 1 Class B





Axis Direction

Horizontal Mounting



Vertical Mounting



The Device can be mounted on a horizontal or vertical surface as shown above

Part Numbering

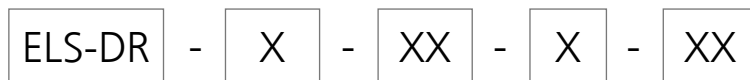

Series Prefix

Switching Angle Adjustable Range:

- 2 : 0.2 to 1.7° adjustable in 0.1° steps
- 5 : 1.8 to 4.8° adjustable in 0.2° steps

Filter frequency:

- 0.5 : 0.5Hz filter
- 1 : 1Hz filter
- 2 : 2Hz filter

Temperature Compensation:

- 1 : No additional temperature compensation
- 2 : Temperature compensated over the range of -10 to 60°C

Customer specific options (optional)

Example:

ELS-DR-2-0.5-2

- Switching angle when adjustment switch is at lowest setting : 0.2°
- Switching angle when adjustment switch is at highest setting : 1.7°
- Frequency response : 0.5Hz
- Temperature compensated over the range -10 to 60°C



Cable Details

1. Core wires, tin plated copper, 7x0.2mm strands per conductor (24 AWG). 8 conductors colours brown, green, yellow, grey, white, pink, blue and red. PVC core insulation.
2. Braided screen of tin copper wire with minimum 85% coverage.
3. PVC dark grey outer jacket
4. Approvals: UL AWM Style 2464, CSA AWM III A

Parameter	Value	Unit
Approximate Weight	73	g/m
Operating Temperature	-40 to 80	°C
Conductor Resistance	100	Ω/Km
Test Voltage	1.5	KV DC
Voltage Rating	300	V
Core Current Rating	2	A
Individual Core Diameter	1.25	mm
Overall Diameter	6.5	mm

Wiring Information

The Tilt sensor has an eight wire connection. The brown and green wires are used for the power supply and the other wires are connected to the two relay switch contacts. **The unit is not fused internally.** On a vehicle system it should be connected to a supply from the fuse box with a 0.25A rating, or connected using an inline 0.25A fuse. Please see the schematic opposite and the table below for connection details.

Wire Colour	Terminal Block Pin	Function
White	1	Relay 1 normally open
Grey	2	Relay 1 common
Yellow	3	Relay 1 normally closed
Green	4	GND
Brown	5	+Ve Supply
Pink	6	Relay 2 normally closed
Blue	7	Relay 2 common
Red	8	Relay 2 normally open

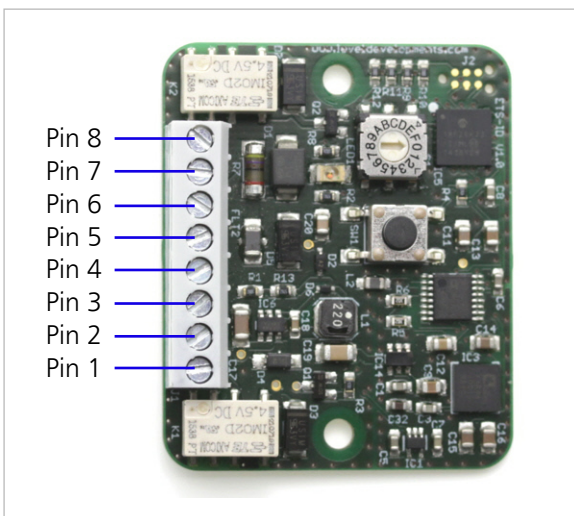
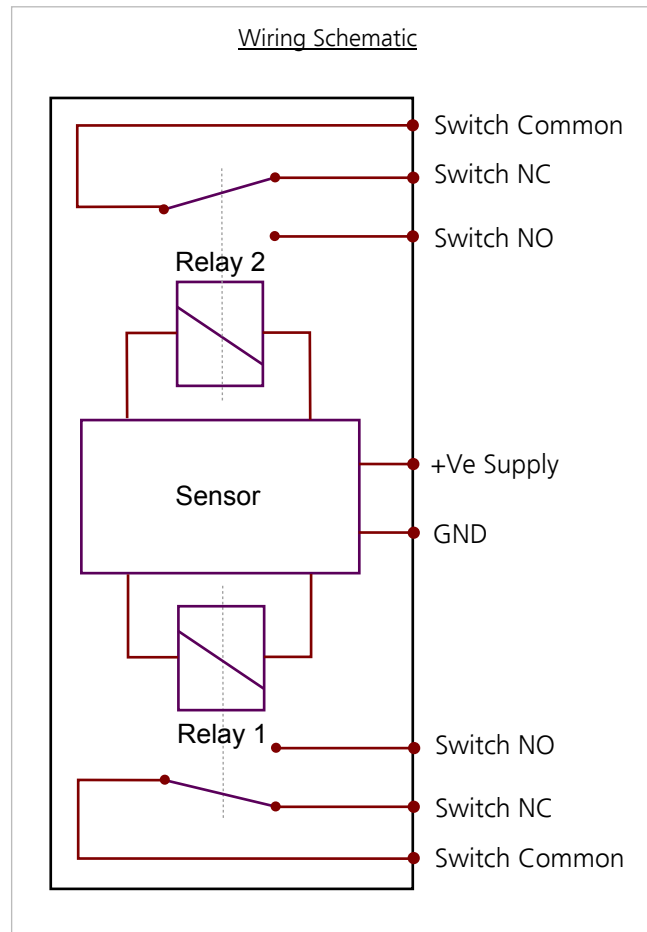



Operating Instructions

Setting the Relay Tilt Threshold Angle

The tilt threshold can be adjusted to set the angle at which the relays will trigger. The range of adjustment will depend on the model purchased (see table). The tilt threshold is set via the small rotary switch on the PCB.

The rotary switches have 16 positions labelled 0-9 and then A-F. This allows the trip angle to set with a range of 16 values between the maximum and minimum values. The switches can be adjusted with a small screwdriver. Once set, the lid should be screwed back in position and the unit is now ready to use.

Setting The Zero Position

The tilt switch will operate when the threshold angle is reached with respect to an absolute level plane. If however the unit is not mounted perfectly level any zero error can be removed using the zero set switch. This is a small push button switch on the printed circuit board inside the housing. Carefully press and release the switch taking care not to touch any of the other components on the PCB. After pressing, the LED on the PCB will blink to indicate that the button press has been successful.

Mode Of Operation

When tilted clockwise from zero, when the angle exceeds the set threshold, relay 1 will be switched on. It will only switch off when the angle returns to zero (or below). When tilted counter clockwise from zero, when the angle exceeds the set threshold, relay 2 will be switched on. It will only switch off when the angle returns to zero (or above).

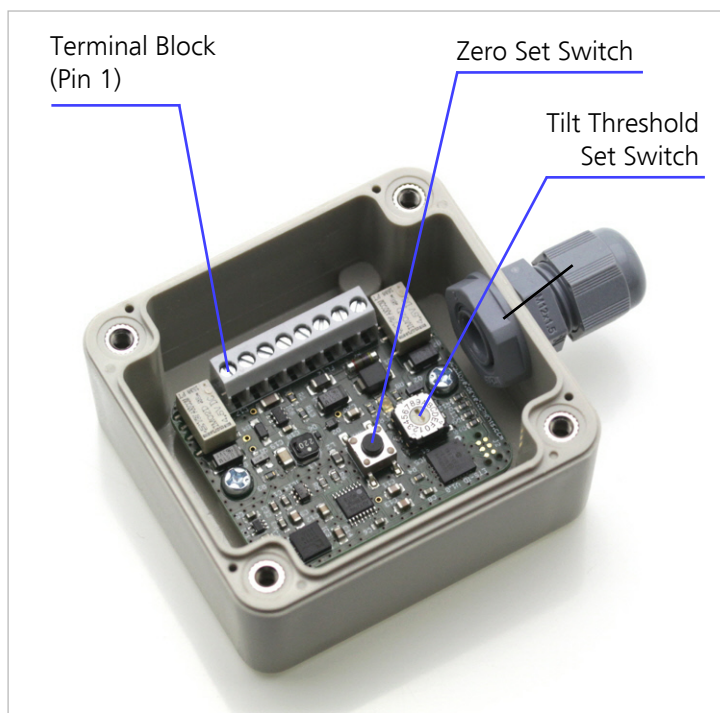

Switch Position	Trip Threshold Angle	
	ELS-DR-2	ELS-DR-5
	0.2°	1.8°
	0.3°	2.0°
	0.4°	2.2°
	0.5°	2.4°
	0.6°	2.6°
	0.7°	2.8°
	0.8°	3.0°
	0.9°	3.2°
	1.0°	3.4°
	1.1°	3.6°
	1.2°	3.8°
	1.3°	4.0°
	1.4°	4.2°
	1.5°	4.4°
	1.6°	4.6°
	1.7°	4.8°